

Please check actual product in box for bracket type used

GREAT GATSBY 450X1200D

PRODUCT CODE
 GG45120D

LED MIRROR

SPECIFICATIONS

WIDTH	450mm
HEIGHT	1200mm
DEPTH	31mm
WEIGHT	10kg
ORIENTATION	Portrait/Landscape

LIGHTING SPECIFICATIONS

CCT	2700K - 6500K
CRI	>80

INSTALLATION

Wall mount
Hardwire
Input voltage: 220-240v 50Hz

FEATURES

Copper Free Mirror
LED Lighting (Adjustable Colour Temperature)
Backlit
Touch Sensor
Demister with 1 Hour Auto Cut-off

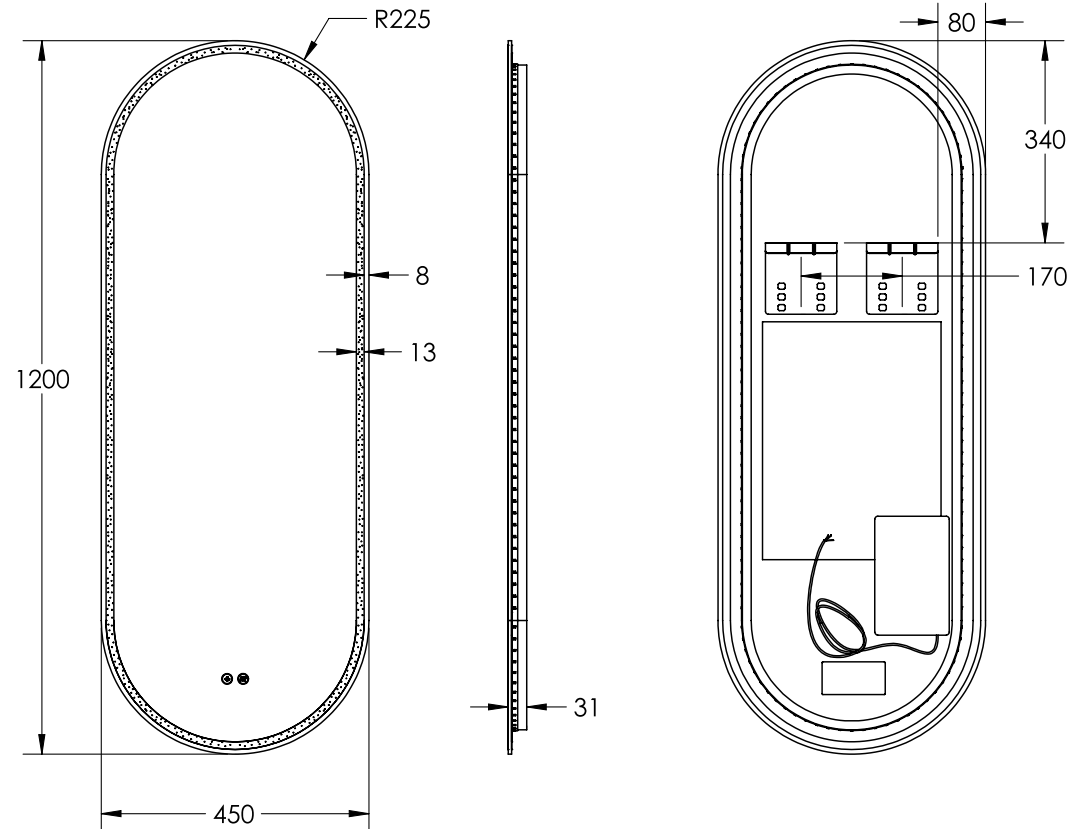

Disclaimer: All LED Products requiring hardwiring must be installed by a licensed electrician in accordance with local regulations. Sizes are in mm and nominal and should be checked prior to installation. Actual colours may vary so please check colour samples before ordering. Installation is acceptance of our products. Installation of faulty, warped, chipped or damaged products will void our warranty.

Please check actual product in box for bracket type used

GREAT GATSBY 450X1200D

LED MIRROR

PRODUCT CODE
GG45120D

SPECIFICATIONS

WIDTH	450mm
HEIGHT	1200mm
DEPTH	31mm
WEIGHT	10kg
ORIENTATION	Portrait/Landscape

FEATURES

- Copper Free Mirror
- LED Lighting
(Adjustable Colour Temperature)
- Backlit
- Touch Sensor
- Demister with 1 Hour Auto Cut-off

LIGHTING SPECIFICATIONS

CCT	2700K - 6500K
CRI	>80

INSTALLATION

- Wall mount
- Hardwire
- Input voltage: 220-240v 50Hz

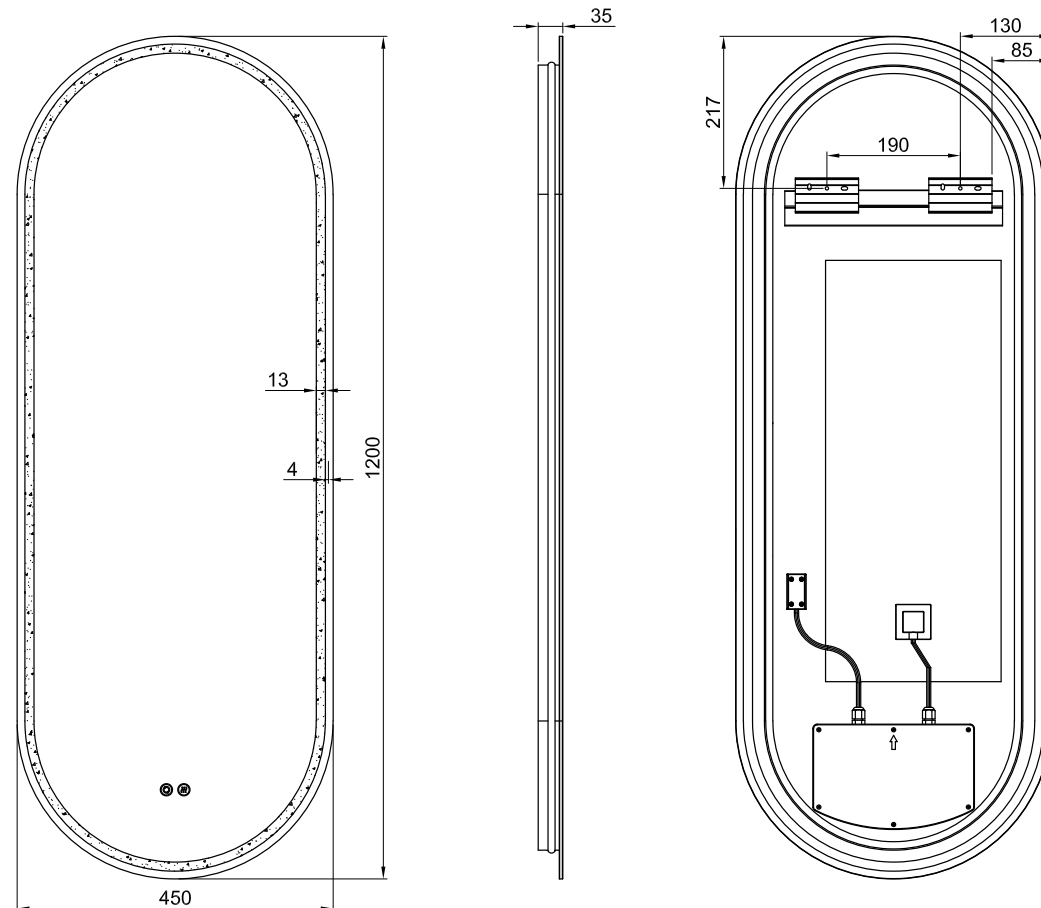

Disclaimer: All LED Products requiring hardwiring must be installed by a licensed electrician in accordance with local regulations. Sizes are in mm and nominal and should be checked prior to installation. Actual colours may vary so please check colour samples before ordering. Installation is acceptance of our products. Installation of faulty, warped, chipped or damaged products will void our warranty.

Please check actual product in box for bracket type used (Hardwire/Plug)
 Modubox™

GREAT GATSBY 450X1200D

LED MIRROR

PRODUCT CODE

GG45120D

SPECIFICATIONS

WIDTH	450mm
HEIGHT	1200mm
DEPTH	31mm
WEIGHT	10kg
ORIENTATION	Portrait/Landscape

LIGHTING SPECIFICATIONS

CCT	2700K - 6500K
CRI	>80

INSTALLATION

Wall mount
Hardwire
Input voltage: 220-240v 50Hz

FEATURES

Copper Free Mirror
LED Lighting (Adjustable Colour Temperature)
Backlit
Touch Sensor
Demister with 1 Hour Cut-Off
Modubox™

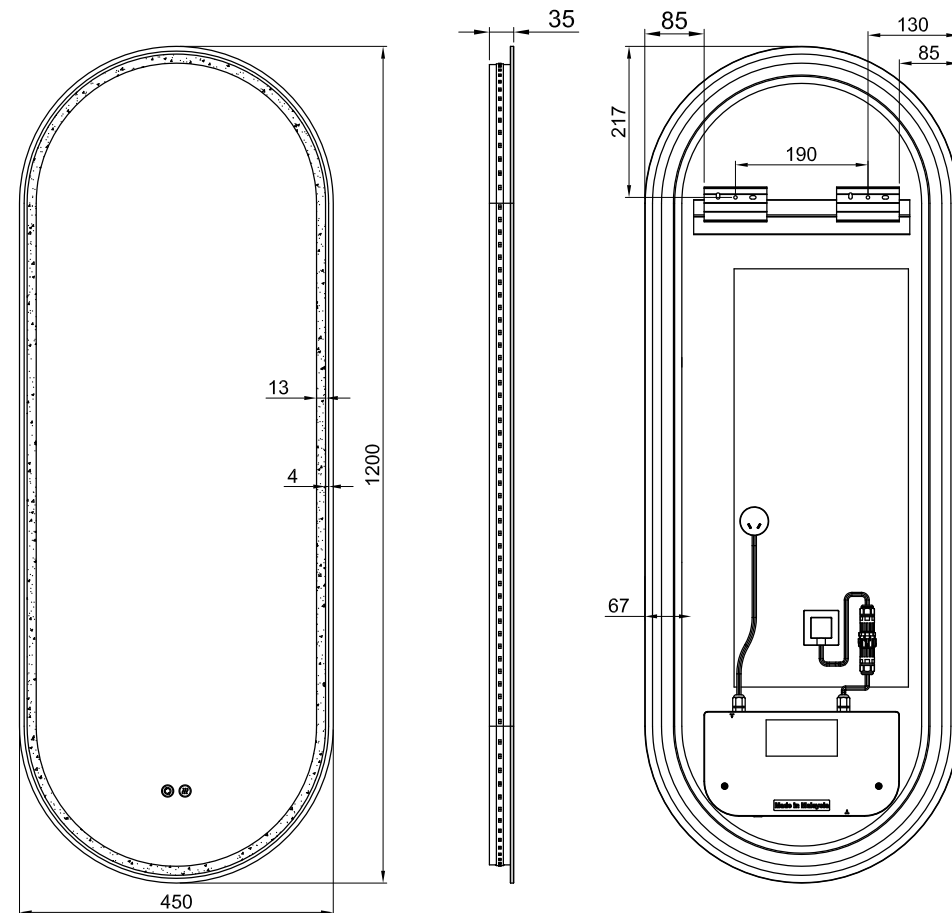

Disclaimer: All LED Products requiring hardwiring must be installed by a licensed electrician in accordance with local regulations. Sizes are in mm and nominal and should be checked prior to installation. Actual colours may vary so please check colour samples before ordering. Installation is acceptance of our products. Installation of faulty, warped, chipped or damaged products will void our warranty.

 13-15 Edison Road, Dandenong South VIC 3175
 T (03) 9706 6663 E sales@remer.com.au W remer.com.au

Please check actual product in box for bracket type used

GREAT GATSBY 450X1200D

LED MIRROR WITH ALUMINIUM FRAME

SPECIFICATIONS

WIDTH	455mm
HEIGHT	1205mm
DEPTH	40mm
WEIGHT	11kg
ORIENTATION	Portrait/Landscape

LIGHTING SPECIFICATIONS

CCT	2700K - 6500K
CRI	>80

INSTALLATION

Wall mount
Hardwire
Input voltage: 220-240v 50Hz

FEATURES

Copper Free Mirror
LED Lighting (Adjustable Colour Temperature)
Backlit
Touch Sensor
Demister with 1 Hour Auto Cut-off

FINISH	PRODUCT CODE
Baltic Brass	G45120D-BB
Brits Nickel	G45120D-BN
Cuban Bronze	G45120D-CB
Georgian Metal	G45120D-GM

FINISH	PRODUCT CODE
Manhattan Black	G45120D-MB
Milano White	G45120D-MW
Nordic Gold	G45120D-NG

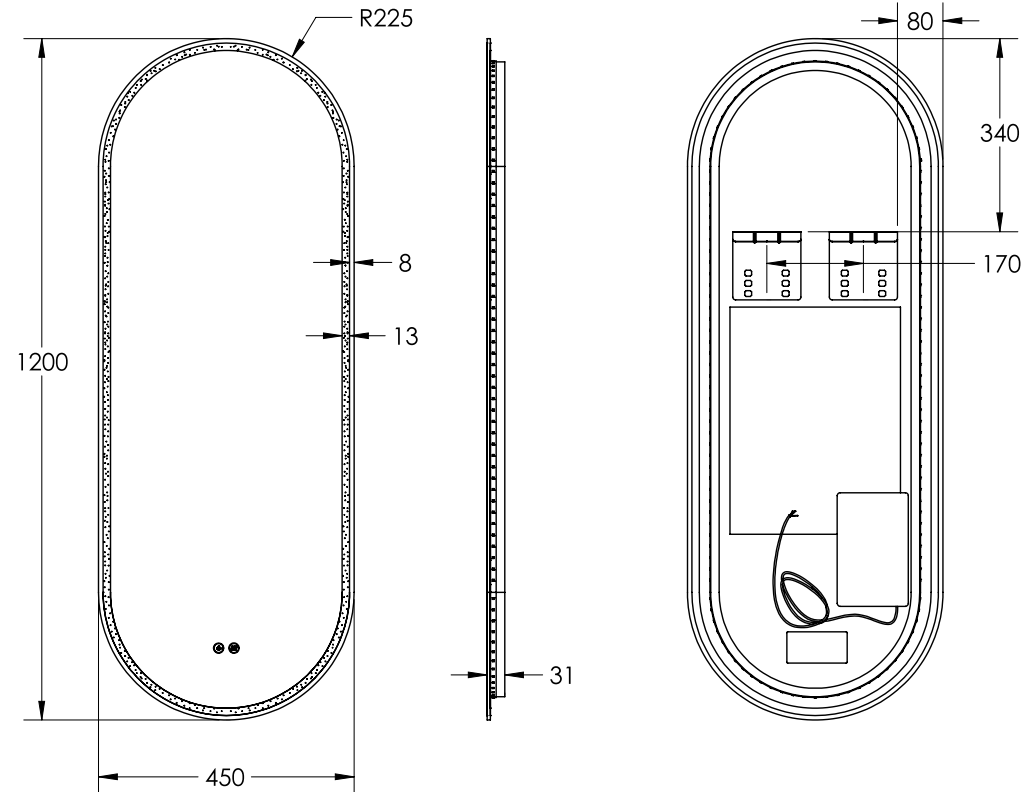

Disclaimer: All LED Products requiring hardwiring must be installed by a licensed electrician in accordance with local regulations. Sizes are in mm and nominal and should be checked prior to installation. Actual colours may vary so please check colour samples before ordering. Installation is acceptance of our products. Installation of faulty, warped, chipped or damaged products will void our warranty.

Please check actual product in box for bracket type used

GREAT GATSBY 450X1200D

LED MIRROR WITH ALUMINIUM FRAME

SPECIFICATIONS

WIDTH	455mm
HEIGHT	1205mm
DEPTH	40mm
WEIGHT	11kg
ORIENTATION	Portrait/Landscape

LIGHTING SPECIFICATIONS

CCT	2700K - 6500K
CRI	>80

INSTALLATION

Wall mount
Hardwire
Input voltage: 220-240v 50Hz

FEATURES

Copper Free Mirror
LED Lighting (Adjustable Colour Temperature)
Backlit
Touch Sensor
Demister with 1 Hour Auto Cut-off

FINISH	PRODUCT CODE
Baltic Brass	G45120D-BB
Brits Nickel	G45120D-BN
Cuban Bronze	G45120D-CB
Georgian Metal	G45120D-GM

FINISH	PRODUCT CODE
Manhattan Black	G45120D-MB
Milano White	G45120D-MW
Nordic Gold	G45120D-NG

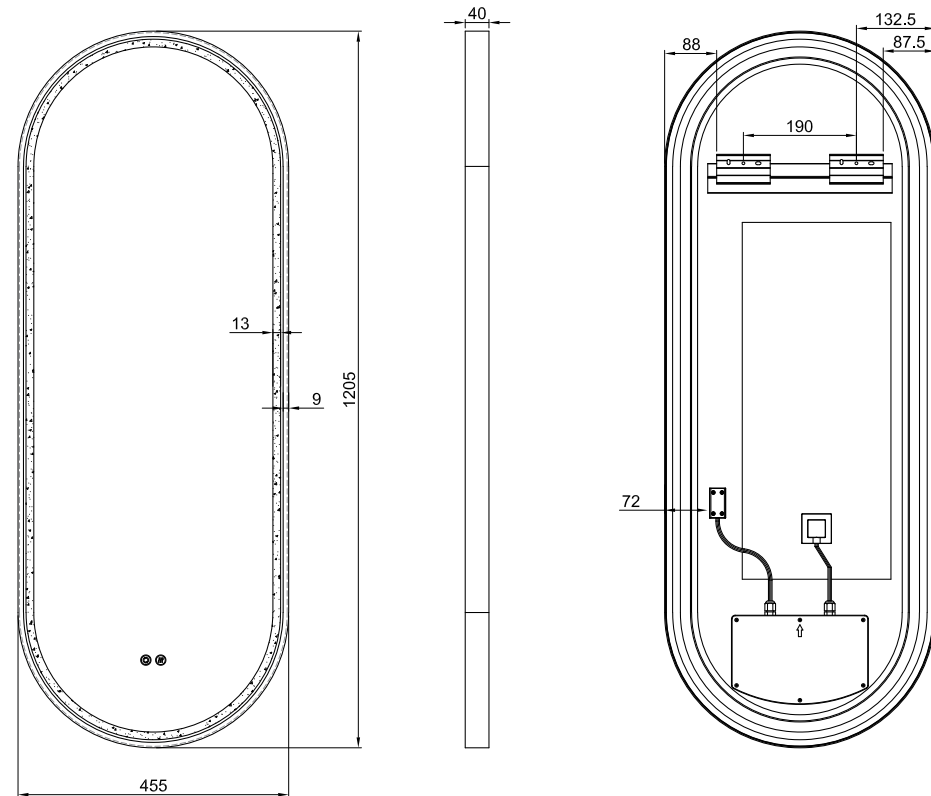

Disclaimer: All LED Products requiring hardwiring must be installed by a licensed electrician in accordance with local regulations. Sizes are in mm and nominal and should be checked prior to installation. Actual colours may vary so please check colour samples before ordering. Installation is acceptance of our products. Installation of faulty, warped, chipped or damaged products will void our warranty.

Please check actual product in box for bracket type used (Hardwire/Plug)
 Modubox™

GREAT GATSBY 450X1200D

LED MIRROR

PRODUCT CODE

GG45120D

SPECIFICATIONS

WIDTH	450mm
HEIGHT	1200mm
DEPTH	31mm
WEIGHT	10kg
ORIENTATION	Portrait/Landscape

LIGHTING SPECIFICATIONS

CCT	2700K - 6500K
CRI	>80

INSTALLATION

Wall mount
Hardwire
Input voltage: 220-240v 50Hz

FEATURES

Copper Free Mirror
 LED Lighting (Adjustable Colour Temperature)
 Backlit
 Touch Sensor
 Demister with 1 Hour Cut-Off
 Modubox™

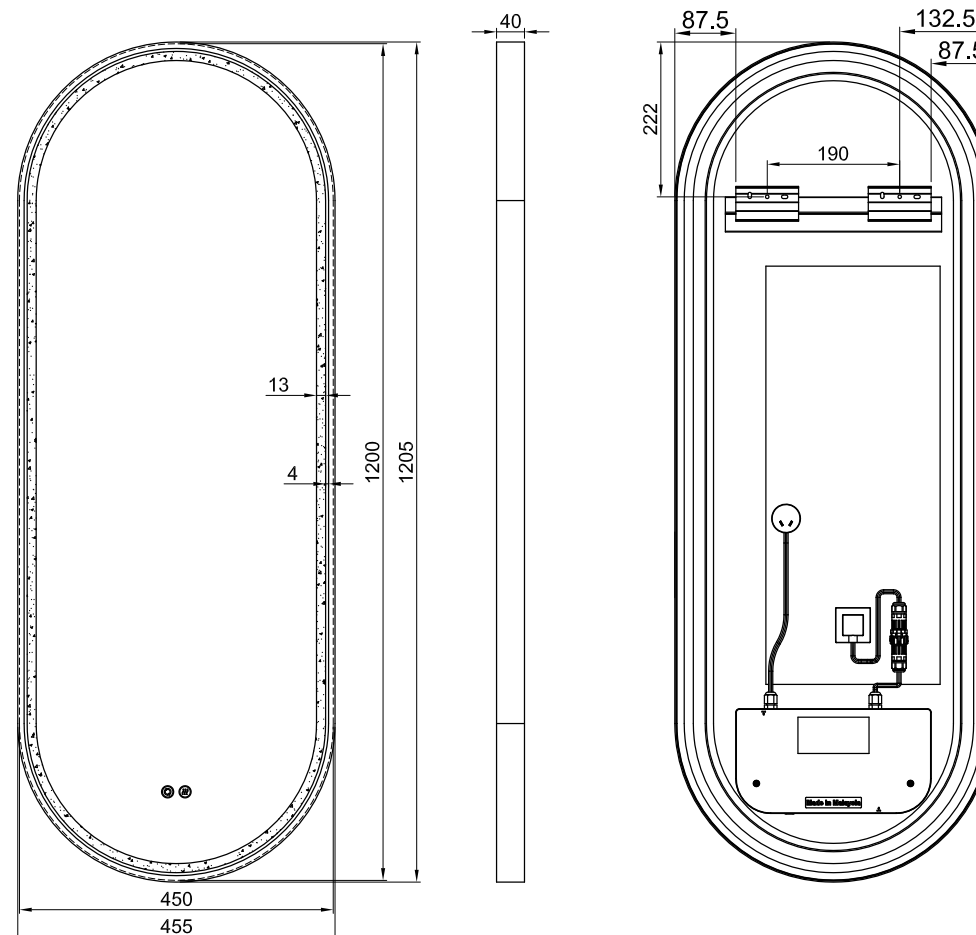

Disclaimer: All LED Products requiring hardwiring must be installed by a licensed electrician in accordance with local regulations. Sizes are in mm and nominal and should be checked prior to installation. Actual colours may vary so please check colour samples before ordering. Installation is acceptance of our products. Installation of faulty, warped, chipped or damaged products will void our warranty.

13-15 Edison Road, Dandenong South VIC 3175
 T (03) 9706 6663 E sales@remer.com.au W remer.com.au